



## ***SUSPENSION SETUP GUIDE***

For your Pivot suspension equipped bike to pedal and descend at its best, it is important to tune the suspension properly. Use this guide to familiarize yourself with the Pivot suspension setup procedures and as a baseline for tuning to your individual riding needs.

### **Document Contents:**

- 1. Setting Sag on *FOX Float DPS* and *Float X* Rear shocks**
- 2. Setting Rebound damping on *FOX Float DPS* and *Float X* Rear Shocks**
- 3. Setting Compression damping on *FOX Float DPS* and *Float X* Rear Shocks**
- 4. Setting up *FOX Float X2 Air***
- 5. Setting up *FOX Float* air fork pressure**
- 6. Setting up *FOX Float* air fork compression and rebound damping**

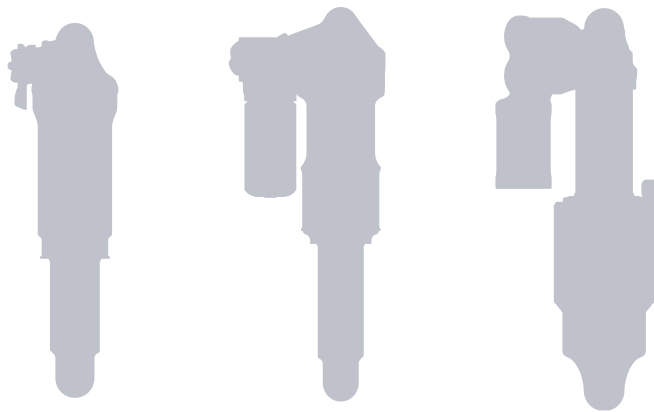

**Performance. Redefined.**

## 1. Setting Sag on FOX Float DPS, and Float X Rear shocks

Always set sag with the compression adjust *blue* lever turned to the open position (see section 3 for details on this setting).

1. If it is not installed already, attach the sag indicator to the bottom of the shock body using the provided zip-tie. (fig 1)
2. Have the rider stand on the pedals, preferably with their hydration pack on, and have them sit down hard into the saddle to achieve accurate sag settings. The rider does not need to bounce up and down nor should they sit down gently. If they sit down hard once, the suspension will cycle well into the stroke and return to the natural sag setting with the rider in the saddle.
3. With the rider in the saddle and not moving, slide the O-ring up into position against the air can. (fig 3)
4. Once the O-ring is set in place, have the rider slowly step off the bike so as not to move the O-ring.
5. Make adjustments to the sag by removing or adding air so that steps 2-4 result in the O-ring lining up with the red line on the sag indicator (fig 5). Some of our models feature a sag indicator with both a blue line (RACE) and a red line (TRAIL). You can set the sag anywhere in this range to achieve a firmer or plusher overall feel depending on rider preference. *For shocks with the EVOL can:* It will be necessary to cycle the shock after adding or subtracting air before re-checking sag as the large Evol negative air chamber will need to equalize pressure with the main chamber each time air is added or removed. You can do this by pushing down on the saddle several times to compress the shock past the sag point. It is OK to do this with the shock pump still attached to the shock as it will let you know how much the pressure increases or decreases after the Evol negative air chamber balances with the main chamber.

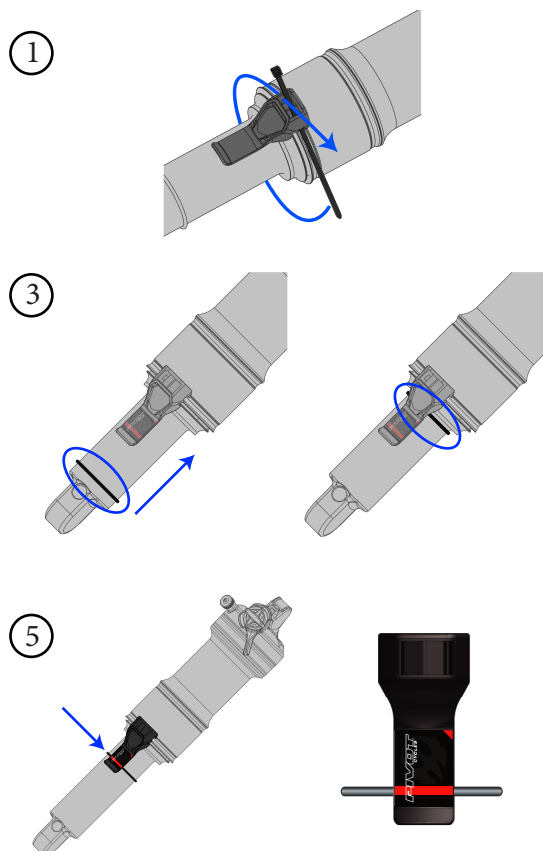

**WARNING:** MAKE SURE TO ROTATE SAG INDICATOR TO BOTTOM OF SHOCK BEFORE RIDING TO ENSURE THAT IT DOES NOT BREAK OFF WHEN SUSPENSION CYCLES

If there is no sag indicator on the shock, use the measurements listed below to determine sag. Different models and sizes of Pivot bikes use different length shocks and therefore require different sag settings.

Indicator A* Sag: 0.74" (18.8mm)*	Indicator B Sag: 0.65" (16.5mm)	Indicator C Sag: 0.49" (12.4mm)	Indicator D Sag: 0.55" (14.0mm)
Bikes: • Mach 5.7 • Mach 5: M-XL • Mach 6 Carbon* • Mach 6 Alloy* • Firebird*	Bikes: • Switchblade • Mach 5.5 • Mach 5.7 Carbon • Mach 4: S-XL (2010 & Older) • Mach 5: XS-S • Mach 429 Alloy	Bikes: • Mach 4: XXS-XS	Bikes: • Mach 4: S-XL (2011 & Newer) • Mach 429 Carbon • Mach 429 SL • Mach 429 Trail

\*Sag Measurement: 0.80" (20.3mm); set between the red line and the end of the indicator

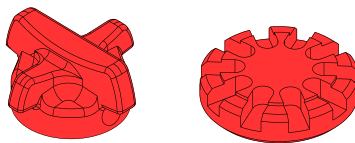

## 2. Setting Rebound damping on FOX Float DPS and Float X Rear Shocks:

We set rebound from the most open or fastest position, so start by turning the *red* rebound dial counterclockwise all the way out and then follow the guidelines below per model:

- Mach 4, 429SL, and Mach 5.7: Turn *red* dial in clockwise 0-6 clicks in depending on rider weight. A sub 130lb rider is at the full out or fastest setting. Average is 4 clicks in.
- Mach 429 Trail: Turn *red* dial in clockwise 3-8 clicks in depending on rider weight. Average is 5 clicks in.
- Switchblade and Mach 5.5: Turn *red* dial in clockwise 5-10 clicks in depending on rider weight. Average is 6 clicks in.
- Mach 6 or Firebird with Float X or Float DPS: Turn *red* dial in clockwise 9-13 clicks in depending on rider weight.

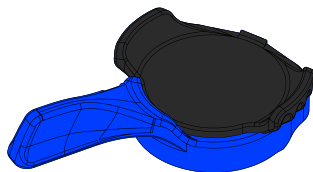

## 3. Setting Compression damping on FOX Float DPS and Float X Rear Shocks:

Because all dw-link® equipped Pivot bikes pedal so efficiently, we use the compression lever as a tuning tool for rider weight and compression support. All bikes can be run with the *blue* lever in full open and perform very well. On Float DPS shocks, this means the lever is turned towards the opposite side of the air valve. In the case of the Float X, this means that the lever will be flipped towards the remote reservoir. Lighter riders under 160lbs will generally run in the full open position most of the time. Riders in the 170lb+ range and more aggressive riders who like the feel of more mid-stroke support will generally prefer the middle setting. The firm setting is great for your ride to the trail, long fire road climbs, and smooth XC race courses where a more locked out feel is desired.

All Factory Series Float X and Float DPS shocks also feature three additional options that affect the open setting via the *black* knob. This knob needs to be lifted slightly to turn to one of the three designated options. #1 is the most open, or least amount of compression damping, and #3 is the firmest (but still slightly less firm than the middle position of the *blue* lever). You can experiment with all of these options to find the setting that provides the best compression support and plush feel for your weight and riding style. Other than running in the full firm mode on rocky descents, all settings are designed to work well in a wide variety of terrain and rider weights.



#### 4. FOX Float X2 Air:

Start by setting sag using the same process as the Float X and Float DPS shocks (page 2). The sag indicator on this shock is located on the oil reservoir rather than attached to the air sleeve. If there is no sag indicator on the oil reservoir use the measurements listed below to determine sag. Different models and sizes of Pivot bikes use different length shocks and therefore require different sag settings. The bike models for each sag setting are listed under the respective diagrams.



- Bikes:
- Switchblade
  - Mach 5.5

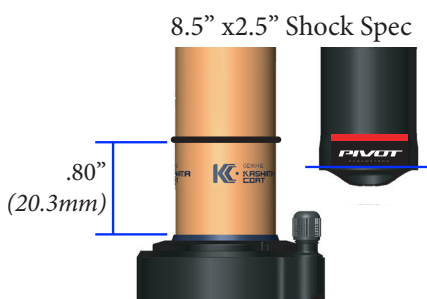

- Bikes:
- Firebird
  - Mach 6

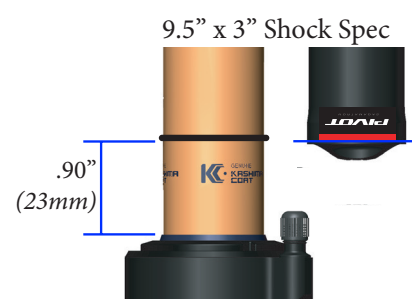

- Bikes:
- Phoenix

#### Damping Adjustments

The X2 air shock has tuning options well beyond the scope of what we can cover here. Not only can the shock be tuned through the use of the HSC, LSC, HSR, and LSR knobs, but it can also be tuned via the amount of air pressure in the shock and the addition or removal of air volume spacers to change the spring curve characteristics. We have settled on an air spring curve that has proven to be optimized for a wide range of riders from a sport level to our World Cup DH team, so changing the Pivot factory air spring curve characteristics is not really necessary.

We recommend 30% sag on the Float X2 Air. Based on this sag setting you can record your air pressure and use FOX's tuning chart copied on the right to set your *High Speed Compression* damping (HSC), *Low Speed Compression* damping (LSC), *High Speed Rebound* damping (HSR), and *Low Speed Rebound* damping (LSR). These settings are also applicable to Performance series Float X2 air shocks that feature only the LSC and LSR adjustments.

For further detail, FOX provides a complete tuning guide for the Float X2 Air shock on their website at [www.ridefox.com](http://www.ridefox.com)

Recommended settings for 2017 FOX Float X2 Air shocks*				
Air Spring Pressure	Baseline LSR (3mm hex)	Baseline HSR (6mm hex)	Baseline LSC (3mm hex)	Baseline HSC (6mm hex)
90	Open	1-3	Open	Open
100	Open-2	2-4	Open-1	Open-2
110	1-3	3-5	Open-2	1-3
120	2-4	4-6	Open-2	2-4
130	2-4	5-7	1-3	3-5
140	3-5	6-8	1-3	3-5
150	4-6	6-8	2-4	4-6
160	4-6	7-9	2-4	4-6
170	5-7	7-9	3-5	5-7
180	5-7	8-10	4-6	6-8
190	6-8	8-10	4-6	6-8
200	7-9	9-11	5-7	7-9
210	8-10	9-11	6-8	8-10
220	9-11	10-12	6-8	8-10
230	10-12	10-12	7-9	9-11
240	11-13	11-13	8-10	9-11
250	12-14	11-13	8-10	10-12

\*Count clicks from open. 0 clicks = Open (fully turned counter-clockwise)

In general, we are running the rebound settings at the slower end of the range provided at each pressure and the compression settings at the lighter end of the provided range. For example, if you are running 200psi in the shock, the range for LSR is listed as 7-9 clicks in from open; We recommend starting at 9. For HSR the range is 9-11 clicks in from open; We recommend starting at 11. On the compression side for LSC, at 200psi in the shock, the range is 5-7 clicks in from open; We recommend starting at 5 clicks in. For HSC the range is 7-9 clicks in from open; We recommend starting at 7. If you follow this same process for the pressure that you are running then you'll have an excellent starting set up that may not require any further adjustment.

## 5. FOX Float Air Fork Pressure:

To set fork sag use the charts below as a recommended starting point:

RIDER WEIGHT (lbs)	32 FLOAT Pressure	34 FLOAT Pressure	36 FLOAT Pressure
<b>120-130</b>	57 psi/ 3.9 bar	45 psi/ 3.1 bar	40 psi/ 2.8 bar
<b>130-140</b>	61 psi/ 4.2 bar	48 psi/ 3.3 bar	41 psi/ 2.8 bar
<b>140-150</b>	66 psi/ 4.5 bar	51 psi/ 3.5 bar	43 psi/ 3.0 bar
<b>150-160</b>	71 psi/ 4.9 bar	53 psi/ 3.7 bar	46 psi/ 3.2 bar
<b>160-170</b>	76 psi/ 5.2 bar	56 psi/ 3.9 bar	51 psi/ 3.5 bar
<b>170-180</b>	82 psi/ 5.6 bar	58 psi/ 4.0 bar	55 psi/ 3.8 bar
<b>180-190</b>	87 psi/ 6.0 bar	63 psi/ 4.3 bar	59 psi/ 4.1 bar
<b>190-200</b>	92 psi/ 6.3 bar	68 psi/ 4.7 bar	63 psi/ 4.3 bar
<b>200-210</b>	98 psi/ 6.7 bar	72 psi/ 5.0 bar	67 psi/ 4.6 bar
<b>210-220</b>	103 psi/ 7.1 bar	77 psi/ 5.3 bar	71 psi/ 4.8 bar
<b>220-230</b>	108 psi/ 7.4 bar	82 psi/ 5.6 bar	75 psi/ 5.2 bar
<b>230-240</b>	113 psi/ 7.8 bar	86 psi/ 5.9 bar	79 psi/ 5.4 bar
<b>240-250</b>	119 psi/ 8.2 bar	91 psi/ 6.3 bar	83 psi/ 5.7 bar

## 6. FOX Float Air Fork Rebound and Compression Damping:

### Setting rebound damping on FOX Forks:

We set rebound from the most open or fastest position, so start by turning the *red* rebound dial on the bottom of the right fork leg counterclockwise all the way out and then follow the guidelines below:

- **Float 32, 34, 36 Fit:** Turn *red* dial clockwise in 5-8 clicks in (depending on rider weight). Most riders are safe with 6 clicks in as a starting point.

### Setting Low Speed Compression damping on FOX Forks:

We set compression from the most open or fastest position, so start by turning the *black* compression inner dial on the top of the right fork leg counterclockwise all the way out and then follow the guidelines below:

- **Float 32, 34, 36 Fit:** Turn *black* dial clockwise in 2-8 clicks in (depending on rider weight). Most riders should feel comfortable with 5 clicks in as a starting point. A rider under 120lbs would start with 2 clicks in.